

Low Flow Indicator

or

Low Flow Indicator with Delta-Q® Precision Flow Regulator

Installation and Operating Instructions

Applies to: LFI3-A-40, LFI3B-A-40 or LFI3-A-40-Q, LFI3B-A-40-Q

General

Smartflow Low Flow Indicator is an in-line device using a high-visibility impeller to show cooling media movement inside process cooling lines with flow between 0.3 and 4 Liters per Minute.

Low flow Indicators are ideal for use in critical injection mold cooling circuits using bubblers or baffles where flow is restricted and effective cooling is essential.

The polysulfone flow body is compatible with common cooling liquids. Wetted parts are made from corrosion-resistant materials in a proven design platform.

Optional temperature and pressure gauges plus Delta-Q flow regulators can be added as needed for increased functionality and suitability to process requirements.

Specifications

Flow Range	0.3 - 4 LPM (0.08 - 1 GPM)
Connection size	1/4", 3/8" or 1/2" NPT or BSPP
Max. Temperature	210°F (99°C)
Max. Pressure.....	100psi (6.9bar)

Component Materials

End Caps	Brass or Glass-Filled Nylon
Flow Body.....	Polysulfone
Impeller	Nylon
Shaft	Stainless Steel
O-Rings	EPDM
Screws.....	Stainless Steel



Installation Best Practices

The flow indicator is line-mounted without additional support.

1. For best results, install the flow indicator with 10 diameters of straight pipe before the inlet of the flow indicator, and 5 diameters of straight pipe after the outlet of the flow indicator.
2. Use a pipe thread sealant compatible with the maximum operating temperature and process fluid. Thread sealant must not contain solvent.
3. Cooling media should be clean and filtered to avoid scale buildup inside the indicator. Impurities in the water are likely to cause scale buildup in cooling lines and deposits causing malfunction of the low flow indicator.
4. Install the flow indicator with the arrow pointing in the direction of flow.

Maintenance

Debris in the circulating system may cause the impeller to stick or discolor the inside of the flow indicator body. Occasional cleaning of the internal parts is recommended for optimum operation.

Clean the flow body with mild, soapy water. **DO NOT CLEAN WITH ACETONE or SOLVENTS.** Do not clean with abrasives that will scratch the window and reduce visibility.

1. Remove the screws in each corner. Remove the flow indicator body and impeller sleeve. Check that the impeller moves freely on the shaft.
2. Thoroughly clean flow path and the flow body.
3. Replace any parts that are worn or broken.
4. Replace o-rings if they are hard, brittle or flattened.
5. Do not over-tighten the screws as this may crack the flow body.

CAUTION

- Use at temperatures above 130°F(54°C) poses a serious personal injury hazard. Use extreme caution, protective clothing, or shielding around the system to minimize risk to personnel and nearby equipment
- Accelerated chemical attack with result if flow indicators are used at elevated pressures and temperatures. Frequently inspect the body for cracking or crazing which may indicate chemical attack. Sudden failure and leakage can result from chemical attack. Consult the chemical compatibility list for substances that attack the polysulfone flow body.
- Any liquid system offers the potential for accidental leakage. Leakage onto electrical or computer equipment could result in costly damage or personal injury. Do not locate piping systems where leakage might damage equipment or pose personal injury hazards. If it is impossible to avoid piping in such locations, use shielding to protect equipment and personnel.

CHEMICAL COMPATIBILITY

The following is a list of chemicals that are not compatible with the UDEL Polysulfone used in the flow indicator body.

Acetone, Methyl Ethyl Ketone	Cyclohexanone	Toluene
Benzene	Esters	1,1,1-Trichloroethane
Carbon Tetrachloride	Freon TA	Trichloroethylene
Chlorobenzene	Methylene Chloride	Xylene
Chloroform	Tetrachloroethylene	
	1,1,2,2-Tetrachloroethane	

Limited Warranty

Seller warrants that Smartflow® products supplied will conform to the description stated in published literature, and that the product will be of standard quality. The seller warrants manufactured components for 90 days. This is the sole warranty made by Seller with respect to this product. Seller expressly disclaims any other express or implied warranties, including, but not limited to, the implied warranty of merchantability and the implied warranty of fitness for a particular purpose.

Seller shall not be liable for any cost or damages, whether direct, incidental or consequential, including, but not limited to, any injury, loss or damage resulting from the use of this product, regardless of whether any claim for such cost or damages is based on warranty, contract, negligence, tort or strict liability. The sole liability of Seller is limited to repairing or replacing this product.

This warranty shall not apply to any products that have been repaired or altered by anyone other than Seller. The warranty shall not apply to any products subject to misuse due to common negligence or accident, nor to any products manufactured by Seller which are not installed or operated in accordance with the printed instructions of Seller or which have been operated beyond the rated capacity of the goods. Seller states that the product’s useful safe life is 5 years. Actual life may vary widely depending on operating environment such as temperature, pressure, and chemical exposure.

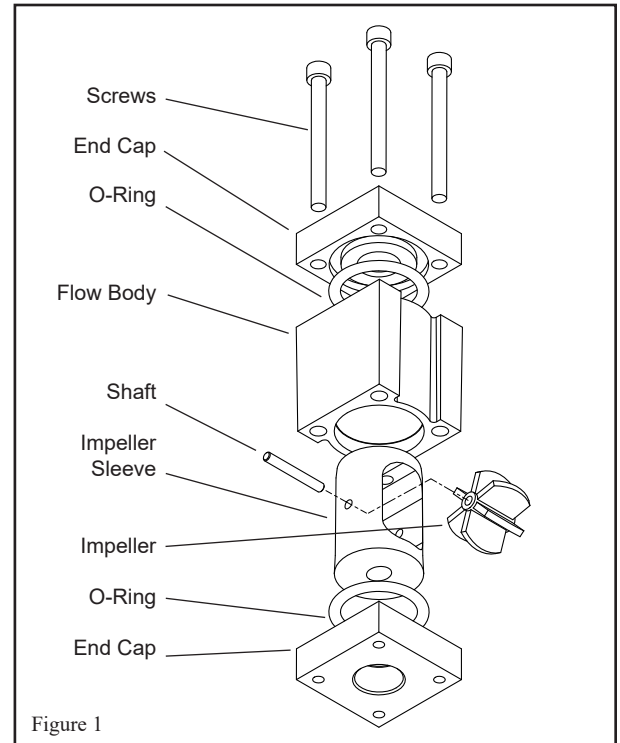

Figure 1

Replacement Parts List

Item	Factory Part Number
Screws *	SHCS-10x24-2.0-SS
O-Ring (2)	568-214-5601-70
Sleeve	LTLF-SLEEVE
Impeller Shaft	EFSH-100
Impeller	LTLF-IMPELLER

* Longer screws will be used if accessories such as pressure or temperature gauges are present. Contact Customer Service for additional replacement parts information if needed.